



This detector has been specially designed to be installed in farms, where high and prolonged exposures to ammonia (NH₃) make it unviable to install detectors fitted with standard sensors.

The combination of an electrochemical sensor with special characteristics, and control by a microprocessor provides, using special algorithms, a highly accurate detector with extremely low maintenance costs throughout its useful life of up to five years.

Its structural design also accounts for the special conditions of this type of facility, making it easy to install suspended above drinking troughs, feed racks, and in particular above an area that achieves the system's best coverage and detection efficacy.

AVAILABLE FORMATS

- 4-20mA with 3-wire connection, compatible with **DURGAS** control panels by means of an optional conversion interface.
- Range 0-100 ppm.

SPECIAL FUNCTIONS

Fitted with a 12bit microprocessor that provides for total and accurate control of the status of the sensor and its electronics. Thermal compensation that achieves a correct response from each electrochemical sensor in the face of temperature variations.

Hardware test.

Digital filter based on variable sampling of the sensor's average values.

Exact automatic zero adjustment. This special function monitors zero in relation to the electronics and sensor response. To do this, the following protocol is used: Every 30 minutes an automatic test is run: if drift is +/- 2% of the scale's total value, it will be readjusted to zero, otherwise it will be displayed as a real reading.

Other functions accessible with the methodology used at the factory allow us to know: the sensor's remaining useful life, the date of manufacture, date of last calibration, and serial number.

APPLICATIONS

This **DURTOX** detector is specially designed for use in farms where the continuous exposure to NH₃ makes it unviable to use conventional detectors.

There is a special conversion module with 8 inputs 4-20mA to RS485 for connection to **DURGAS** control panels, providing in these cases for installation coverage of up to 1km distances.

DURTOX NH₃ extended exposure 4-20mA

TECHNICAL CHARACTERISTICS

Technology	12bit microprocessor and extended exposure electrochemical sensor	Max. loop resistance (4-20mA)	250Ω
Supply voltage	10 to 30V DC	Max. output current (4-20mA)	21.3 mA (Tip)
Approximate consumption	maximum 65mA at 12V DC	Loop fault current (4-20mA)	< 2mA
Useful life	± 5 years in clean air	Optical indicators of sensor and loop failures	By local LED (4-20mA)
Resolution	0.5 ppm	Box Material	High Density Polyethylene
Repeatability	± 2% of the full scale	Maintenance periods	2 years -recommended- life test
Stabilisation Initial Delay -all functions-	5 minutes -approx-	Protection grade	IP65
T90 Response times	≤ 90s	Cable type	3-wire hose (3 x 1.5 m ² Ø)
Temperature and humidity ranges	-10°C to +50°C - 20-90% Hr	Cable input diameter	Hose 6-10mm ²
Operating atmospheric pressure	90-110 Kpa	Maximum installation distance recommended	400/500m, 1000m if the interface is used 4-20 mA to Rs485 conversion
Maximum permitted air speed	<0.1-0.5m/s (depending on the gas)	Dimensions (mm) and weight (g)	Cylinder 110 x 48.25/ 145

FUNCTIONING:

Upon receiving voltage, a stabilisation time of 1 min will begin.

During this time the output current will be 2mA.

Once the stabilisation time has ended, the output current will become 4mA in the absence of gas.

The fault led will light up in the event of an internal failure, or when the output current exceeds 21mA or drops below 2mA.

WIRING

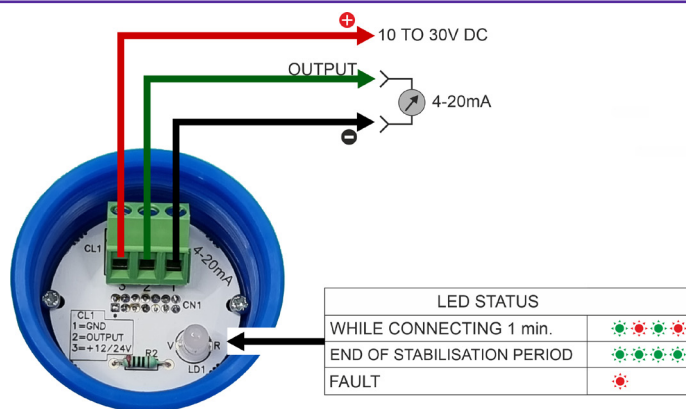

WARRANTY

DURTOX detectors are guaranteed against any manufacturing defect for 1 year from the equipment's date of purchase .

The warranty conditions are set out in the detector's installation manual.

DURAN ELECTRÓNICA S.L reserves the right to make improvements or introduce modifications in this equipment without prior notice.

INFORMATION FOR YOUR ORDERS

When placing your order please provide the correct code for the product required and verify that its description is correct.

DSQS4NH3/Fg DURTOX NH₃ extended exposure 0-100ppm 4-20 mA Cylindrical Plastic Envelope IP65

I-fichaDurtoxNH3_granja_tec 4-20mA-v01